

EASYCOOL 易酷®

—PRIDE Leading New Cryogenic Technologies—

KDE 401SF Cryocooler Operating Manual

TABLE OF CONTENTS

SAFETY

SERVICE

GENERAL INFORMATION

SPECIFICATIONS

CONSTRUCTION

Maintenance and Disclaimer

APPENDIX

(This page is intentionally blank.)

SAFETY

GENERAL

The safety of the equipment of CSIC Pride (Nanjing) Cryogenic Technology Co., Ltd. (Pride) is guaranteed when the installation, operation and service are performed in accordance with the technical manual. You can find the information about Service Center in the service section of this manual.

SPECIAL NOTICES

Three types of special notices -- WARNINGS, CAUTIONS and NOTES are used in this technical manual.

WARNING

pay attention to actions or conditions that can result in injury or death.

CAUTION

pay attention to actions or conditions that can result in damage to the equipment or the abnormal performance.

NOTE

provide important, additional information to explain or suggest related problems or operations.

WARNINGS RELATED TO MAGNETISM

AVOID INJURY.

When cryocooler released in a high magnetic field, ferrous tools and parts can become hazardous projectiles. Do not use ferromagnetic tools when the magnet is at field.

AVOID EXPOSURE.

People with Cardiac Pacemakers, Defibrillators or Ferromagnetic Implants shall avoid exposure to strong magnetic field. Long term effects of high magnetic fields have not be completely discovered. Shorten the personal exposure time in the magnetic field.

WARNINGS RELATED TO CRYOGENICS

AVOID INJURY.

Extreme cold may cause frostbite. Do not touch any parts with frost while handling system components.

Do not splash cryogenic liquids on any areas of clothing or exposed skin, otherwise, skin tissue will get damaged. Always wear eye protection and gloves.

AVOID ASPHYXIATION.

Keep the operation environment properly ventilated.

GENERAL WARNINGS

AVOID ELECTRIC SHOCK.

All electrical supply equipment must meet applicable codes and be installed by qualified personnel.

AVOID INJURY.

Never use compressed helium gas from system without a proper regulator. Overpressure can cause serious injury if the system equipment ruptures.

Always wear eye protection when handling pressurized gas lines and other pressurized equipment. Never heat up the pressurized gas line or other pressurized components.

Disconnect gas lines only when the compressor is stopped. Disconnect the cold head while the gas returns to the room temperature. Material failure and uncontrolled pressure.

Release might cause serious injury.

Please disconnect or connect a gas line coupling to avoid loosening the cold head or compressor coupling according to the compressor operating manual. Gas pressure can project the coupling with enough force to cause serious injury.

CAUTIONS

PRESERVE YOUR WARRANTY.

Modification to equipment without the consent of the manufacturer will void the warranty.

Helium gas with a purity of 99.999% is required. Unqualified helium gas can damage the system and warranty is invalid in this condition.

PREVENT EQUIPMENT DAMAGE.

Only disciplined persons are permitted to install and remove the coldhead.

Damage to gas lines can result from crimping by repeated bending and repositioning.

AVOID GAS LEAKS.

Check the gasket seal on the male half of each Aeroquip coupling. Be sure that the gasket seal is in place and the sealing surfaces both on the male and female halves are clean before connecting. Replace the gasket seal if it is damaged or missing. Keep the gas line couplings aligned when making or breaking a coupling connection. Leaks might occur due to the weight of the gas line or due to a sharp bend near the connection.

AVOID A MALFUNCTION.

Do not allow air to get into the helium gas cryogenic system. Moisture from the atmosphere can seriously degrade the performance of cold head and produce an abnormal noise so that the system can't work normally.

⚠ NOTE!

Please check the ring seal (usually it is black) in the self-sealing connector of the male before connect gas line. For some accidents, the ring seals might be lost. In the accessory, two seals will be supplied. You can use them and put it in the male connector if lost.



ring seal

SERVICE

SERVICE CENTER

Address: No.32 Changqing Road, Jiangning Development District,
Nanjing 211106 P.R.C.

TEL: +86-25-68626268

FAX: +86-25-68626273

E-mail: cryosales@724pride.com

GENERAL INFORMATION

Type Specification: KDE401SA

The KDE401SA Cryocooler is a two-stage G-M cycle cryocooler. The cryogenic temperature depending upon the head load imposed is produced by the cryocooler, especially less than 30 K for the first-stage cold station and less than 3.5K for the second-stage cold station with no head load.

The Cryocooler has three major components: the drive unit; the cylinder; and the displacer-regenerator assembly, which is located inside the cylinder.

With newly developed material and unique structure, the model KDE401SA Cryocooler has a performance of 0.25W at 4.2K at 2nd stage driven by KDC2000A compressor.

Functionally, the high-pressure helium gas from the Compressor Unit will be supplied to the Cryocooler through the helium gas supply connector. The supply gas will pass into the displacer-regenerator assembly, and come out through the displacer-regenerator assembly to the crankcase through the motor housing, and finally return to the Compressor Unit through the helium gas return connector. The helium gas expansion work in the displacer-regenerator assembly will provide cooling power for the first and second-stage coldhead.

SPECIFICATIONS

The specifications of the KDE401SA Cryocooler are summarized in Table 1.1.
The appendix shows the outline view of Cold Head.

Table 1.1 KDE401SA CRYOCOOLER SPECIFICATION

Cooling Capacity* First Stage Second Stage	3W@45K (50Hz) 0.25W@4.2K (50Hz)
Orientation**	Vertical Direction
Ambient Operating Temperature	4-30°C
Helium Gas Pressure (20°C) *** Static Operating (High Side)(for Reference)	1.5-1.55MPa (217-225psig) 2.20-2.30Mpa (319~333psig)
Pressure Relief Valve Setting	1.86-1.96Mpa (270~284psig)
Gas Supply Connector Gas Return Connector	1/2-inch Coupling 1/2-inch Coupling
Dimension (approx) Width Length Height	130mm 270.5mm 442mm
Weight	8.9Kg---approx

* Based on the KDC2000A compressor

**The cooling performance is slightly different with various mounting direction. The vertical direction is the best.

***The operating pressure varies according to the heat load of cold head and temperature around the equipment.

*** Depending on compressors, the charging pressure will change.

CONSTRUCTION

KDE401SA Cryocooler consists of a Cylinder, No.1 Displacer, No.2 Displacer, driver mechanism, and Drive Motor. No.1 Displacer is connected to the Scotch Yoke which can be driven by the Drive Motor through the Crank with Bush so that the rotation of the Drive Motor can be varied to reciprocating motion of Scotch Yoke and Displacers.

The Rotary Valve system is furnished to control the helium gas intake and exhaust timing. The Rotary Valve is also coupled to the Drive Motor through Crank, so intake and exhaust operation is synchronized with the position of the Displacer.

The Displacer is a loose fit in the Cylinder except the top in which it is equipped with a dynamic sliding seal to prevent leakage passed through the clearance between the Displacer and Cylinder.

The Displacers consist of regenerator material which cools the gas when passing downwards to the cold space and heats the gas when passing upwards from the cold space. Rare earth regenerator material is used in the 2nd stage Displacer to produce the cooling capacity at the temperature of 4.2K.

The pressure above and below the Displacer is almost the same except for small pressure drops across the regenerator when gas is flowing through it. Virtually no physical work is required to move the Displacer in the Cylinder. No work is done on the gas and the gas does no work on the Displacer. The pressure in the system increase or decrease due to the operation of the inlet or outlet valves.

Maintenance and Disclaimer

KDE401SA is required to replace the sliding parts inside every 10,000h by the Pride. The following terms are not suitable for maintenance-free:

A. Sale beyond the warranty period (13,5000h for cold head, 27,000h for compressor, 13,5000h for whole system) ;

B. Damage due to force majeure,(earthquakes, fires) ;

C. Not in accordance with instructions for use, and maintenance, ;

D. Use the unauthorized parts for maintenance ;

E. Use the third party for maintenance Without our license.

APPENDIX

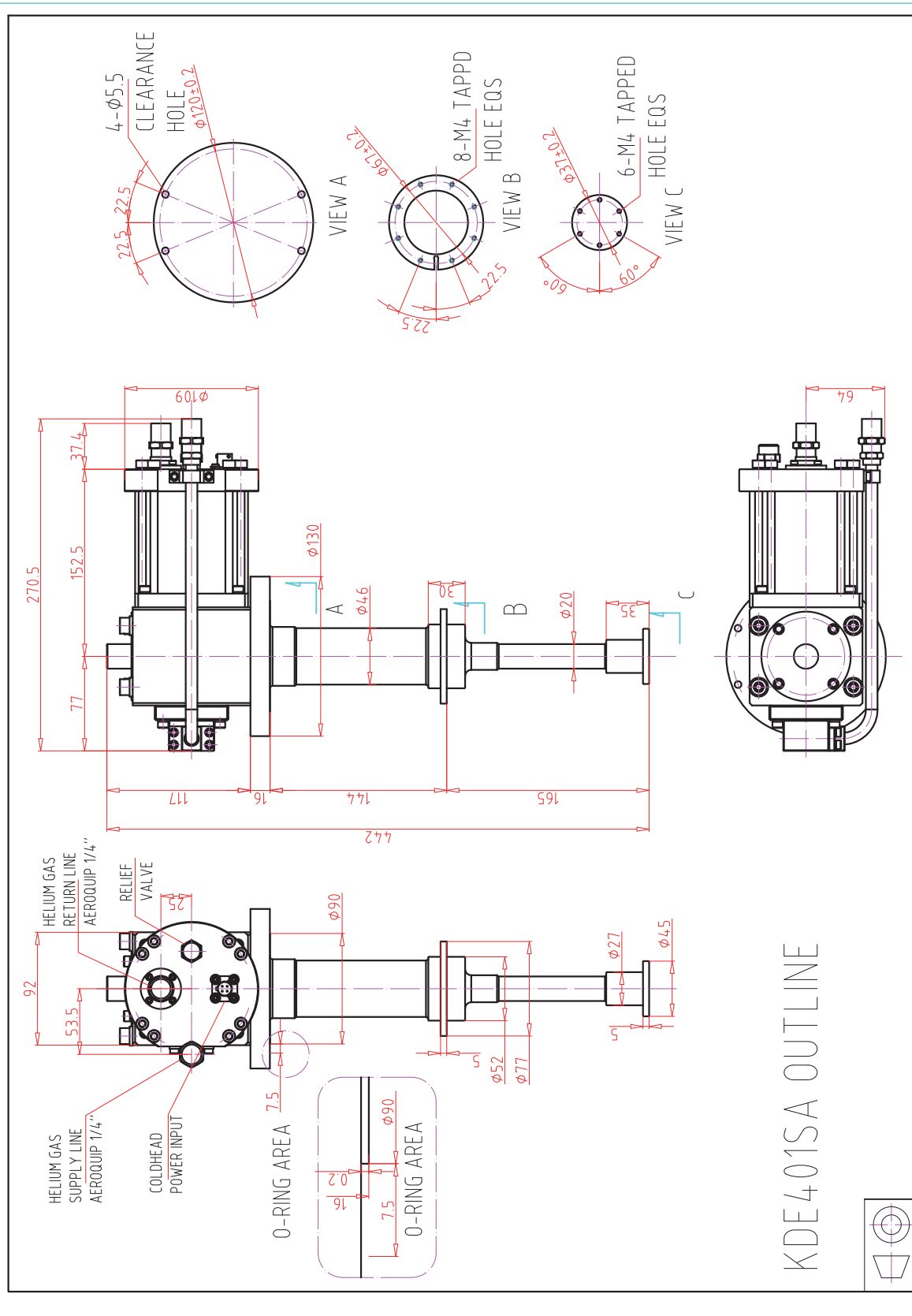

KDE401SA OUTLINE

EASYCOOL 易酷®

PRIDE Leading New Cryogenic Technologies

Tel: +86-25-68626268

Fax: +86-25-68626273

E-mail : cryosales@724pride.com

http : www.724pridecryogenics.com

Add: No.32 Changqing Road, Jiangning

PRIDE Development District, Nanjing 211106 P.R.C.